



AVTECH ELECTROSYSTEMS LTD.

NANOSECOND WAVEFORM ELECTRONICS  
SINCE 1975

□ P.O. BOX 265  
OGDENSBURG, NY  
U.S.A. 13669-0265  
TEL: (315) 472-5270  
FAX: (613) 226-2802

TEL: 1-800-265-6681  
FAX: 1-800-561-1970

e-mail: [info@avtechpulse.com](mailto:info@avtechpulse.com)  
<http://www.avtechpulse.com/>

☒ BOX 5120, LCD MERIVALE  
OTTAWA, ONTARIO  
CANADA K2C 3H4  
TEL: (613) 226-5772  
FAX: (613) 226-2802

## INSTRUCTIONS

MODEL AVP-2S-PS

0 TO 2 VOLTS, 1 MHz

HIGH SPEED PULSE GENERATOR

WITH 50 ps RISE TIME

SERIAL NUMBER: \_\_\_\_\_

### WARRANTY

Avtech Electrosystems Ltd. warrants products of its manufacture to be free from defects in material and workmanship under conditions of normal use. If, within one year after delivery to the original owner, and after prepaid return by the original owner, this Avtech product is found to be defective, Avtech shall at its option repair or replace said defective item. This warranty does not apply to units which have been disassembled, modified or subjected to conditions exceeding the applicable specifications or ratings. This warranty is the extent of the obligation assumed by Avtech with respect to this product and no other warranty or guarantee is either expressed or implied.

### TECHNICAL SUPPORT

Phone: 613-226-5772 or 1-800-265-6681

Fax: 613-226-2802 or 1-800-561-1970

E-mail: [info@avtechpulse.com](mailto:info@avtechpulse.com)

World Wide Web: <http://www.avtechpulse.com>

## TABLE OF CONTENTS

<b>WARRANTY.....</b>	<b>2</b>
<b>TECHNICAL SUPPORT.....</b>	<b>2</b>
<b>TABLE OF CONTENTS.....</b>	<b>3</b>
<b>INTRODUCTION.....</b>	<b>4</b>
<b>AVAILABLE OPTIONS.....</b>	<b>5</b>
<b>SPECIFICATIONS.....</b>	<b>6</b>
<b>INSTALLATION.....</b>	<b>7</b>
<b>VISUAL CHECK.....</b>	<b>7</b>
<b>PLUGGING IN THE INSTRUMENT.....</b>	<b>7</b>
<b>FRONT PANEL CONTROLS.....</b>	<b>9</b>
<b>REAR PANEL CONTROLS.....</b>	<b>10</b>
<b>GENERAL INFORMATION.....</b>	<b>12</b>
<b>BASIC TEST ARRANGEMENT.....</b>	<b>12</b>
<b>AMPLITUDE INTERACTION.....</b>	<b>12</b>
<b>MEASURING RISE TIME.....</b>	<b>13</b>
<b>PREVENTING DAMAGE.....</b>	<b>14</b>
<b>USE CONNECTOR SAVERS.....</b>	<b>14</b>
<b>MECHANICAL INFORMATION.....</b>	<b>15</b>
<b>TOP COVER REMOVAL.....</b>	<b>15</b>
<b>ELECTROMAGNETIC INTERFERENCE.....</b>	<b>15</b>
<b>MAINTENANCE.....</b>	<b>15</b>
<b>REGULAR MAINTENANCE.....</b>	<b>15</b>
<b>CLEANING.....</b>	<b>15</b>
<b>POWER SUPPLY AND FUSE REPLACEMENT.....</b>	<b>16</b>
<b>PERFORMANCE CHECK SHEET.....</b>	<b>18</b>

## INTRODUCTION

The AVP-2S-PS is a high performance instrument capable of generating up to 2V into 50 $\Omega$  loads at repetition rates up to 1 MHz. The rise time is less than 50 ps, and the fall time is less than 200 ps.

Instruments with the "-P" model suffix can generate 0 to +2V, whereas instruments with the "-N" model suffix can generate 0 to -2V.

Instruments with the "-PN" suffix can have two outputs (one positive and one negative). Only one of the two outputs is active at a time.

The output is designed to drive 50 $\Omega$  loads. (A 50 $\Omega$  load is required for proper operation.) The output is AC-coupled.

This instrument is intended for use in research and development laboratories.

### AVAILABLE OPTIONS

The AVP-2S-PS is available with several options:

- EA Option: the output amplitude can be controlled by an externally generated 0 to +10V analog control voltage.
- ECL Option: the input trigger levels are ECL, rather than TTL.
- EO Option: the output offset can be controlled by an externally generated 0 to +10V analog control voltage.
- EW Option: the output pulse width can be controlled by an externally generated 0 to +10V analog control voltage.
- M Option: a monitor output is provided.
- OS Option: an externally generated DC offset can be added to the output.
- OT Option: an internally generated DC offset, controlled by a front-panel dial, can be added to the output.

## SPECIFICATIONS

Model:	AVP-2S-PS
Amplitude <sup>2,3</sup> : (50 Ohm load)	0 to 2 Volts
Pulse width <sup>2</sup> : (FWHM)	0.2 – 4.0 ns
PRF:	0 Hz to 1 MHz
Rise time (20%-80%):	≤ 50 ps
Fall time (80%-20%):	≤ 200 ps
Polarity <sup>4</sup> :	specify -P or -N
Dual Polarity Option Style:	Two outputs (+ and -). Only one active at a time.
Propagation delay:	≤ 70 ns (Ext trig in to pulse out)
Jitter:	±15 ps (Ext trig in to pulse out)
DC offset or bias insertion:	Option available. Apply required DC offset or bias in the range of ± 50 Volts (250 mA max) to back panel solder terminal. See note 5.
Trigger required:	+5 Volt, 50 ns to 500 ns (TTL). ECL trigger option available. See note 7.
Monitor output option <sup>6</sup> :	Provides a 20 dB (x10) attenuated coincident replica of main output
Connectors:   OUT TRIG MONITOR <sup>6</sup>	SMA BNC SMA
Power requirement:	120 / 240 Volts, 50 - 60 Hz
Dimensions (H x W x D):	100 mm x 215 mm x 375 mm (3.9" x 8.5" x 14.8")
Chassis material:	Anodized aluminum, with blue plastic trim.
Mounting:	Any
Temperature range:	+5°C to +40°C

- 1) -PS suffix indicates line powered instrument requiring external trigger. (See <http://www.avtechpulse.com/formats> for details of the four basic instrument formats).
- 2) For analog electronic control (0 to +10V) of amplitude, pulse width or DC offset suffix model number with -EA or -EW or -EO. Electronic control units also include standard front-panel controls. -EW not available on -B units.
- 3) For operation at amplitudes of less than 20% of full-scale, best results will be obtained by setting the amplitude near full-scale and using external attenuators on the output.
- 4) Indicate desired polarity by suffixing model number by -P or -N (i.e. positive or negative) or -PN for dual polarity option.
- 5) For externally applied DC offset option suffix model number with -OS. The Avtech AVX-T bias tee can also be used to obtain DC offset. For internally generated DC offset option (0 to ±5V) add suffix -OT or -EO to model number. (The -OT option is controlled by a front-panel dial, whereas the -EO option can be controlled by a front-panel dial or by an external 0 to +10V voltage).
- 6) For monitor option add suffix -M.
- 7) For ECL trigger option, add suffix -ECL.

## INSTALLATION

### VISUAL CHECK

After unpacking the instrument, examine to ensure that it has not been damaged in shipment. Visually inspect all connectors, knobs, and handles. Confirm that a power cord is with the instrument. If the instrument has been damaged, file a claim immediately with the company that transported the instrument.

### PLUGGING IN THE INSTRUMENT

Examine the rear of the instrument. There will be a male power receptacle, a fuse holder and the edge of the power selector card visible. Confirm that the power selector card is in the correct orientation.

For AC line voltages of 110-120V, the power selector card should be installed so that the “120” marking is visible from the rear of the instrument, as shown below:



For AC line voltages of 220-240V, the power selector card should be installed so that the “240” marking is visible from the rear of the instrument, as shown below:



If it is not set for the proper voltage, remove the fuse and then grasp the card with a pair of pliers and remove it. Rotate horizontally through 180 degrees. Reinstall the card and the correct fuse.

In the 120V setting, a 0.5A slow blow fuse is required. In the 240V setting, a 0.25A slow blow fuse is required.



## FRONT PANEL CONTROLS

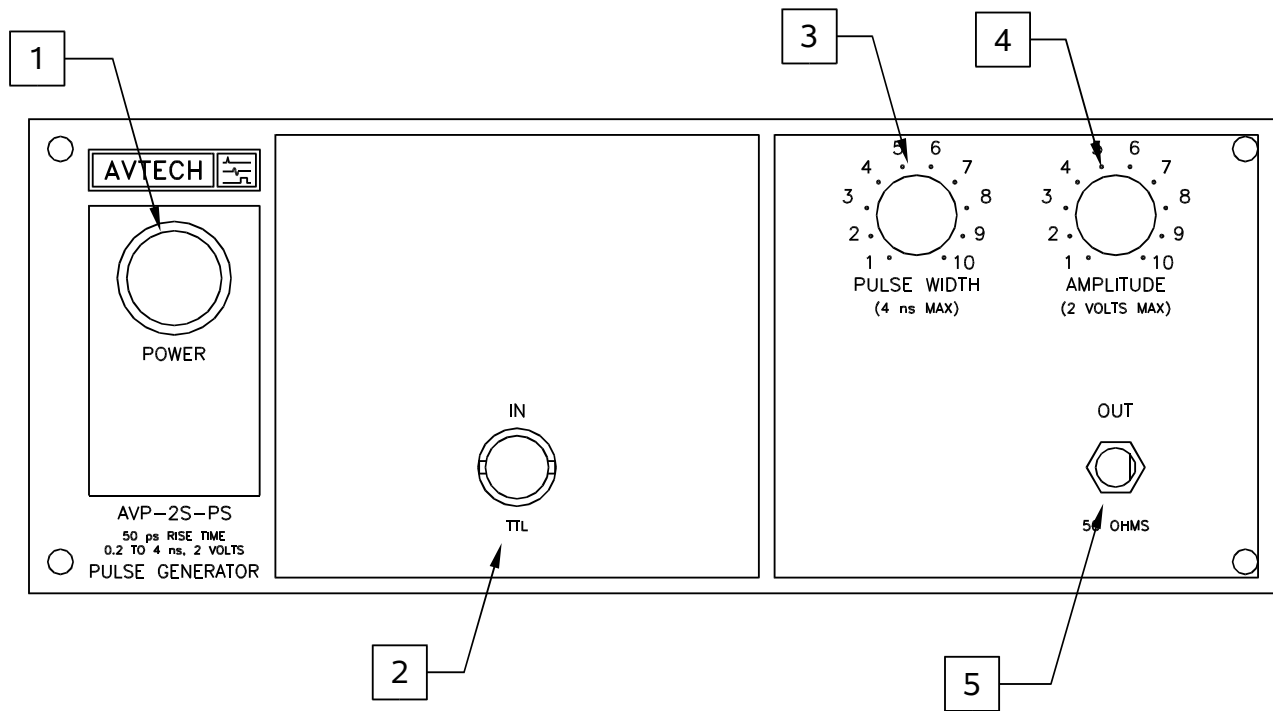

- 1) POWER Switch. The POWER push button switch applies AC prime power to the primaries of the transformer, turning the instrument on. The push button lamp (#382 type) is connected to the internal +15V DC supply.
- 2) IN Connector. The instrument is triggered by a TTL pulse applied to this connector. The input trigger pulse width must be at least 50 ns.
- 3) Pulse Width Control. This dial controls the pulse width.
- 4) Amplitude Control. This dial controls the pulse amplitude.
- 5) OUT Connector. This SMA connector provides the main output. This output *requires* a 50Ω load to function properly

## REAR PANEL CONTROLS

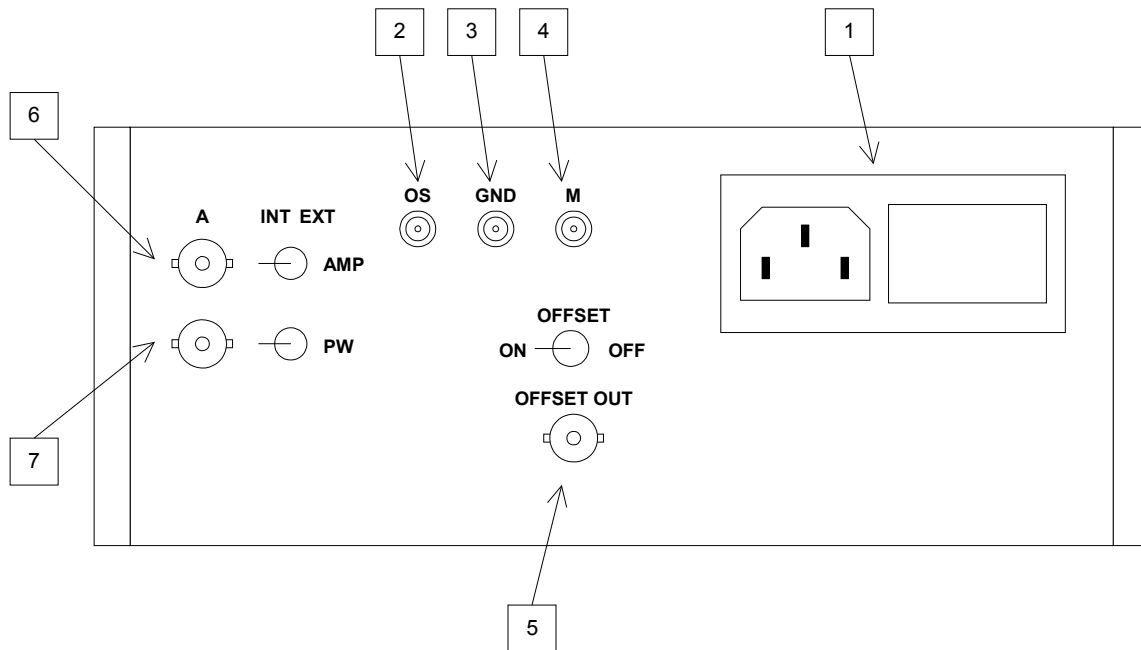

1. **AC POWER INPUT.** A three-pronged recessed male connector is provided on the back panel for AC power connection to the instrument. Also contained in this assembly is a slow-blow fuse and a removable card that can be removed and repositioned to switch between 120V AC in and 240V AC in.

For AC line voltages of 110-120V, the power selector card should be installed so that the “120” marking is visible from the rear of the instrument.

For AC line voltages of 220-240V, the power selector card should be installed so that the “240” marking is visible from the rear of the instrument.

If it is not set for the proper voltage, remove the fuse and then grasp the card with a pair of pliers and remove it. Rotate horizontally through 180 degrees. Reinstall the card and the correct fuse.

In the 120V setting, a 0.5A slow blow fuse is required. In the 240V setting, a 0.25A slow blow fuse is required. See the “Installation” section for more details.

2. **OS INPUT CONNECTOR.** (Present on units with -OS option only.) A DC offset in the range of  $\pm 50V$  (250 mA max) may be applied to this solder terminal. The DC offset will appear on the output. When this feature is not used, the OS input should be connected to ground (using the adjacent GND connector). This is especially important when driving loads containing a diode.

3. GND CONNECTOR. (Present on units with -OS option only.) This solder terminal is connected to ground. It may be used to ground the OS input connector.
4. M OUTPUT CONNECTOR. (Present on units with -M option only.) This SMA connector output provides a 20 dB attenuated coincident replica of main output, for monitoring purposes.
5. OFFSET ON/OFF SWITCH & OUTPUT. (Present on units with -EO or -OT options only). This switch enables the offset feature when it is set to “ON”. When it is set to “OFF”, no offset is added to the output. The internally generated offset is available at the “OFFSET OUT” BNC connector, for monitoring purposes. To add an offset to inverted pulses on units with the dual polarity option (-PN), connect this terminal to the DC terminal of the inverting transformer (see the “POLARITY INVERSION” sections in this manual for further details).
6. AMP SWITCH & INPUT. (Present on units with -EA option only.) To control the output amplitude with an external voltage, set the rear-panel switch to the “EXT” position and apply 0 to +10V to the adjacent connector ( $R_{IN} \geq 10k\Omega$ ).
7. PW SWITCH & INPUT. (Present on units with -EW option only.) To control the output pulse width with an external voltage, set the rear-panel switch to the “EXT” position and apply 0 to +10V to the adjacent connector ( $R_{IN} \geq 10k\Omega$ ).

## GENERAL INFORMATION

### BASIC TEST ARRANGEMENT

The AVP-2S-PS should be tested with a sampling oscilloscope with a bandwidth of at least 10 GHz to properly observe the high-speed waveform. A typical test arrangement is shown below:

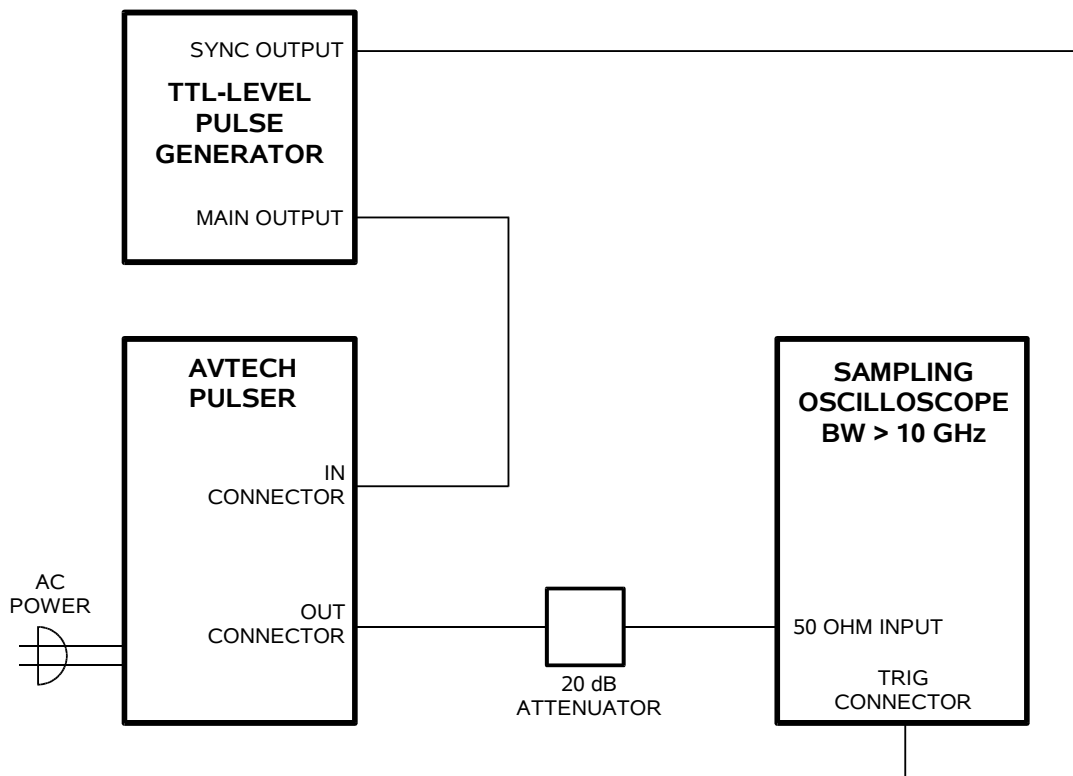

The attenuators may be required to prevent damage to the sampling oscilloscope. A 20 dB attenuator with sufficient voltage rating should be used on the main output.

### AMPLITUDE INTERACTION

Some properties of the output pulse may change as a function of the amplitude setting. For some demanding applications, it may be desirable to use a combination of external attenuators and the amplitude pot to achieve the desired output amplitude.

## MEASURING RISE TIME

The rise time of the AVP-2S-PS is unusually fast, and special care must be taken when measuring the output rise time. All cabling, attenuators, and oscilloscopes must have a bandwidth of at least 10 GHz (ideally 20 GHz).

The coaxial cabling should be a high-bandwidth semi-rigid type. Flexible cables such as RG-174 or RG-58 are not suitable. See “Technical Brief #6, What Coaxial Cable Should I Use?” at <http://www.avtechpulse.com/appnote/techbrief6/> for suggested high-performance cable types.

Any oscilloscope used to observe the rise time will introduce some rise time degradation of its own. If the rated rise time of the oscilloscope is  $t_{SCOPE}$ , and the rise time of the pulser is  $t_{PULSER}$ , the observed rise time will be:

$$t_{OBSERVED} \approx \sqrt{(t_{PULSER}^2 + t_{SCOPE}^2)}$$

Avtech rise times are measured on a 20% to 80% basis (not 10% to 90%).

## PREVENTING DAMAGE

The AVP-2S-PS may fail if triggered at a PRF greater than 1 MHz.

This unit is designed to operate into a load impedance of 50 Ohms and the output stage will be damaged if it is operated into an open circuit (or any other high impedance). Failures due to improper output loading are not covered by the warranty.

The lifetime of the switching elements in the pulse generator module is proportional to the running time of the instrument. For this reason the prime power to the instrument should be turned off when the instrument is not in use.

## USE CONNECTOR SAVERS

If the output cabling is frequently being changed or disconnected, we recommend that you employ "connector savers" such as M/A-Com's model 2082-5133-02 or Pasternack's model PE9506 to reduce mechanical fatigue on the output connector. The connector saver will degrade and wear with frequent use but can be easily replaced in the field.

## MECHANICAL INFORMATION

### TOP COVER REMOVAL

If necessary, the interior of the instrument may be accessed by removing the four Phillips screws on the top panel. With the four screws removed, the top cover may be slid back (and off).

Always disconnect the power cord before opening the instrument.

There are no user-adjustable internal circuits. For repairs other than fuse replacement, please contact Avtech (info@avtechpulse.com) to arrange for the instrument to be returned to the factory for repair.



Caution: High voltages are present inside the instrument during normal operation. Do not operate the instrument with the cover removed.

### ELECTROMAGNETIC INTERFERENCE

To prevent electromagnetic interference with other equipment, all used outputs should be connected to shielded 50Ω loads using shielded 50Ω coaxial cables. Unused outputs should be terminated with shielded 50Ω coaxial terminators or with shielded coaxial dust caps, to prevent unintentional electromagnetic radiation. All cords and cables should be less than 3m in length.

## MAINTENANCE

### REGULAR MAINTENANCE

This instrument does not require any regular maintenance.

### CLEANING

If desired, the interior of the instrument may be cleaned using compressed air to dislodge any accumulated dust. (See the “TOP COVER REMOVAL” section for instructions on accessing the interior.) No other cleaning is recommended.

## POWER SUPPLY AND FUSE REPLACEMENT

This instrument has three main fuses, plus two spares. One, which protects the AC input, is located in the rear-panel power entry module, as described in the “Rear Panel Controls” section of this manual. If the power appears to have failed, check the AC fuse first.

The other two fuses (plus two spares) are located on the internal DC power supply, as shown below:

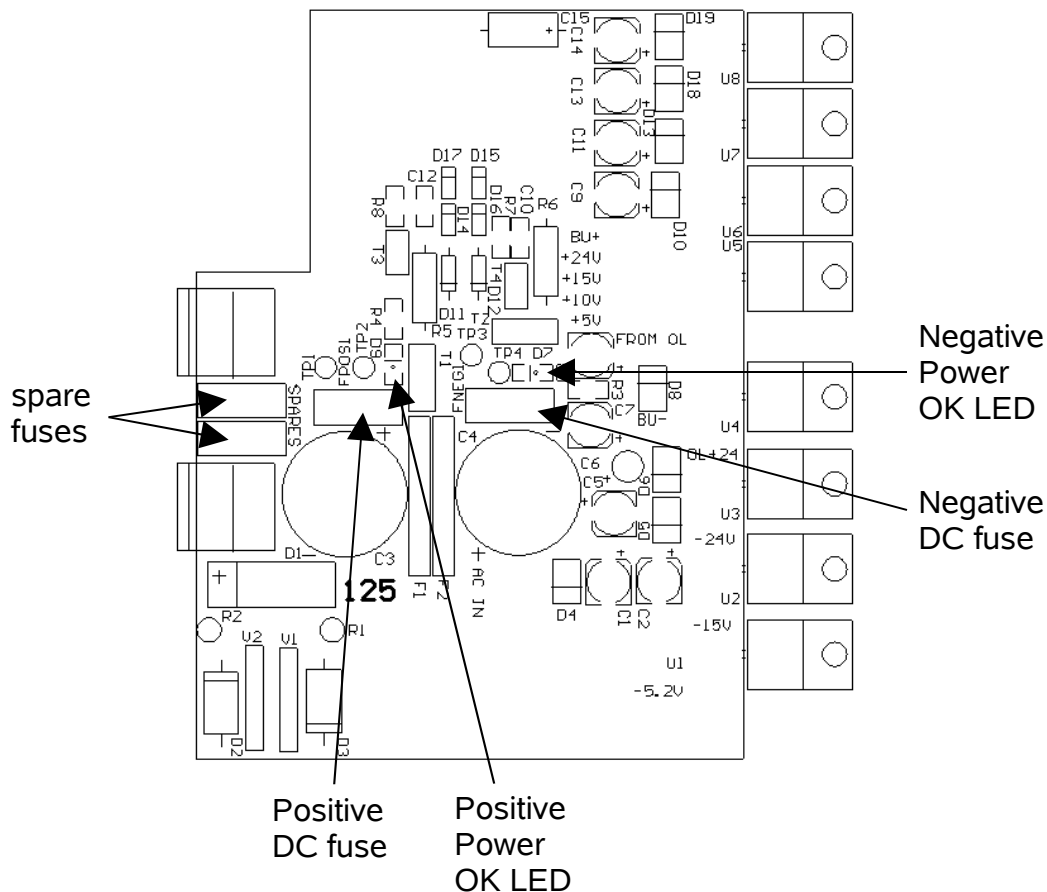

The four fuses on this circuit board are 0.5A slow-blow fuses, Littlefuse part number R452.500. (This fuse can be ordered from Digikey, [www.digikey.com](http://www.digikey.com). The Digikey part number is F1341CT-ND).

If you suspect that the DC fuses are blown, follow this procedure:

1. Remove the top cover, by removing the four Phillips screws on the top cover and then sliding the cover back and off.
2. Locate the two “Power OK” LEDs on the power supply circuit board, as illustrated above.



3. Turn on the instrument.
4. Observe the “Power OK” LEDs. If the fuses are not blown, the two LEDs will be lit (bright red). If one of the LEDs is not lit, the fuse next to it has blown.
5. Turn off the instrument.
6. If a fuse is blown, use needle-nose pliers to remove the blown fuse from its surface-mount holder.
7. Replace the fuse. (Two spare 0.5 Amp fuses are provided on the circuit board. They may be transferred to the active fuse locations using needle-nose pliers.)

PERFORMANCE CHECK SHEET